



// ONE BRAND // ONE SOURCE // ONE SYSTEM



// SERVICE // MATERIAL PROCESSING // SURFACE PROTECTION // AUTOMOTIVE

## REMALOX HD 35

Optimum impact and wear protection

Our high-quality REMALOX HD 35 segment plates provide optimum impact and wear protection. You avoid unnecessary cost for maintenance and downtime, thereby increasing the productivity of your machinery and equipment many times over.



# REMALOX HD 35

## Optimum impact and wear protection

### Fields of application

Due to its composite construction REMALOX HD 35 is especially suitable for applications, where in addition to abrasion, impact energy plays a major role. While the rubber matrix absorbs impact energy, vulcanized  $Al_2O_3$ -ceramic cylinders protect the surface against abrasive wear.

The additional metal layer on the undersurface enables easy fitting on the application areas.

REMALOX HD 35 segment plates have proven optimal performance in applications with high delivery volumes of broken material, long maintenance intervals and construction unfavourable impact angles.

### Typical field of use

- Material transfer stations
- Vibratory grinding machine
- Hopper lining
- Chute lining

### Benefits

- Protection against extreme wear and impact due to composite construction
- Modified curb stones providing high stability
- Long service life
- Easy and fast installation
- Technical consultation and service on-site by trained REMA TIP TOP personnel

### Technical properties

Ref. No.	539 8980	539 8970
Dimensions (L X B X H)	500 x 500 x 35 mm	500 x 250 x 35 mm
Weight	26,0 kg	13,0 kg
Composition	5 mm steel sheet, 10 mm rubber, 20 mm ceramic cylinders with $\varnothing$ 20 mm	

### Fastening recommendation

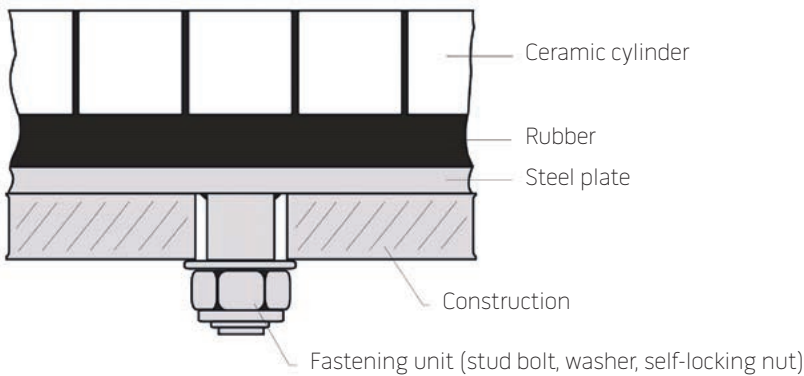

**REMA TIP TOP AG**  
 Gruber Strasse 65 · 85586 Poing / Germany  
 Phone: +49 8121 707-0  
 Fax: +49 8121 707-10 222  
 info@tiptop.de  
[www.rema-tiptop.com](http://www.rema-tiptop.com)

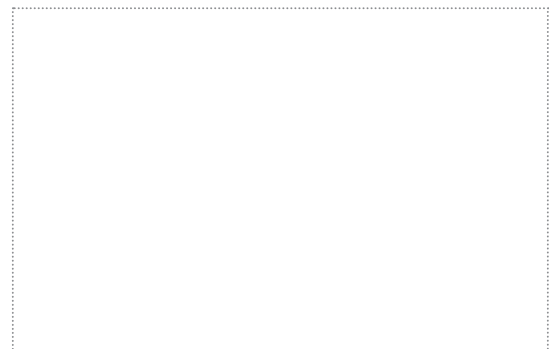

Your local contact

